

Telephone (01803) 875 222
 Unit 19, Bulleigh Barton Farm and
 commercial units, TQ12 5UA
sales@handle-it.com
www.handle-it.com

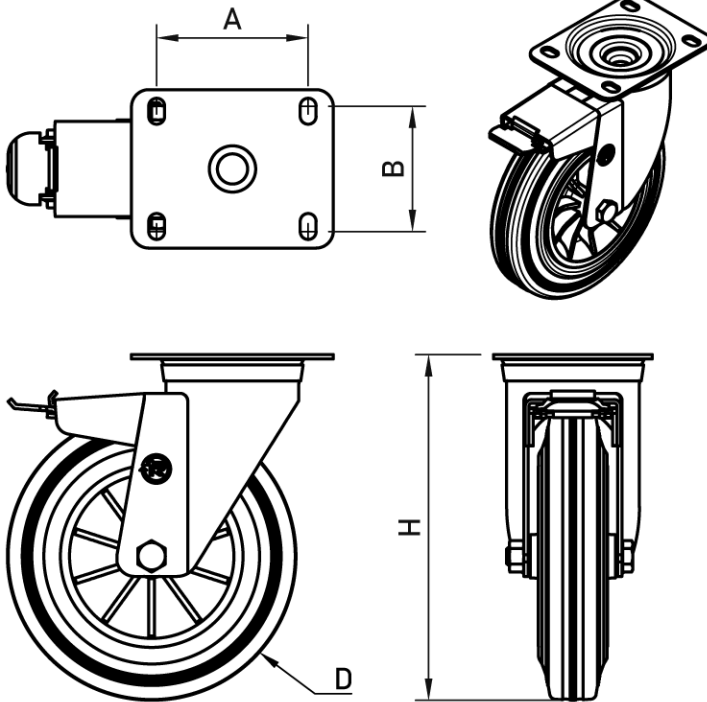

Castor Enquiry Form

Use this sheet to fill out details on the castor you require for a simple enquiry then save the file as a pdf and email to Sales@Handle-it.com. Alternatively, copy the table from this file into an email and enter information into the spaces

This sheet is designed for simple enquiries. If you require a more complex order, please email sales@handle-it.com, or phone 01803 875 222 to chat with the team.

Item	Measurements
Capacity	(kg)
Overall Height (H)	(mm)
Wheel Diameter (D)	(mm)
Distance Between Bolts (A) & (B)	(mm)
Castor Bracket Type	
Tyre Material	
Other Notes	

FOR SECURITY REASONS, PLEASE SAVE AS A PDF FILE BEFORE SENDING IT BACK TO US



Handling Your Handling Needs
 VAT Registration Number 836 905013
 Company Number 4637039

